

## Solenoid operated spool valve

### Flange construction

- ◆ 4/2-way impulse valve execution detented
- ◆ 4/3-way with spring centred mid position
- ◆ 4/2-way with spring reset
- ◆  $Q_{max} = 30 \text{ l/min}$
- ◆  $p_{max} = 350 \text{ bar}$

## DESCRIPTION

Direct operated solenoid spool valve with 4 connections in 5 chamber design. With the solenoids deenergised, the spool is held in the center position by the spring (4/3), or switched back to the offset position (4/2). With the impulse spool (4/2), the spool is held in the switching position by the detent. The pressure tight encapsulated Ex-protection solenoid coil prevents an explosion on the inside penetrating to the outside as well as an ignitable surface temperature.

## CERTIFICATES

	Surface	Mining	Standard -25 °C to...	Z604 -40 °C to...
ATEX / UKEX	x	x	x	x
IECEX	x	x	x	x
CCC	x	x	x	x
EAC	x	x	x	x
Australia	x	x	x	x
MA		x	x	
USA / Canada	x		x	x
PESO	x		x	x

The certificates can be found on [www.wandfluh.com](http://www.wandfluh.com)

## SYMBOL

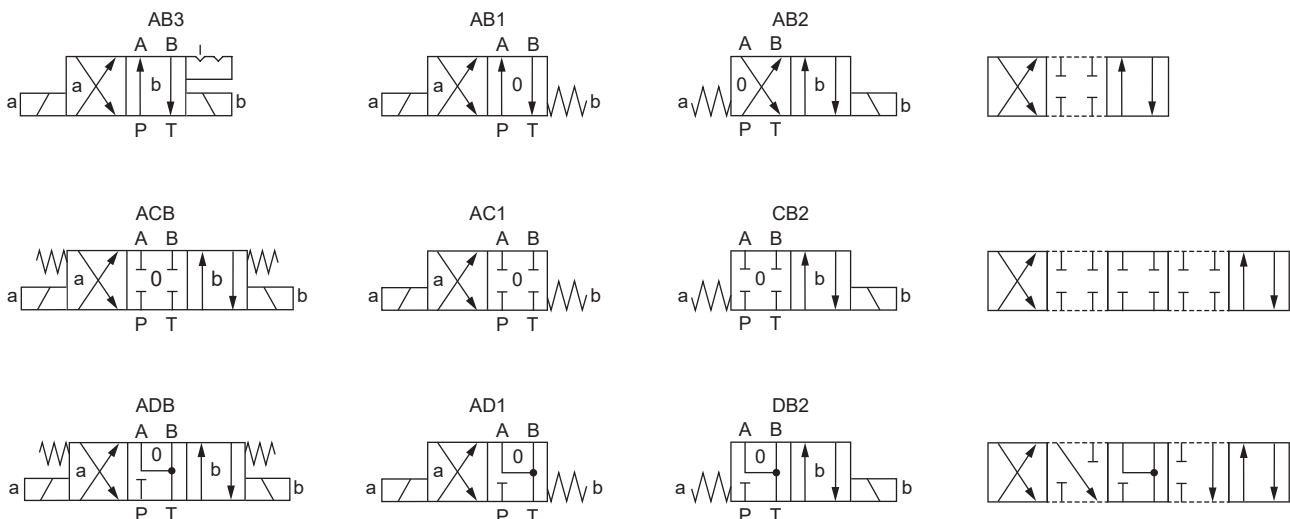

## NG4-Mini Wandfluh standard

Ex db IIC T6, T4 Gb (Zone 1)  
 Ex tb III C T80 °C, T130 °C Db (Zone 21)  
 Ex db I Mb  
 ⓧ II 2 G Ex db IIC T6, T4  
 ⓧ II 2 D Ex tb III C T80 °C, T130 °C  
 ⓧ I M2 Ex db I Mb  
 Class I, Division 1, Group A, B, C, D T4  
 Class II & III, Division I, Group E, F, G T4

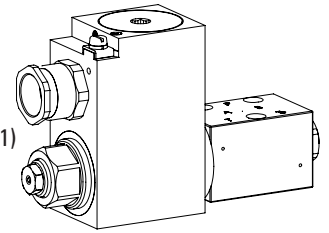

## APPLICATION

These valves are suitable for applications in explosion-hazard areas, open cast and also in mines. Spool valves are mainly used for controlling direction of movement and stopping of hydraulic cylinders and motors. Miniature valves are used where both, reduced dimensions and weight are important.

## ACTUATION

Actuation	Switching solenoid, wet pin push type, pressure tight
Execution	MKY45 / 18x60 (data sheet 1.1-183)
Connection	Cable gland for cable Ø 6,5... 14 mm

**Attention!** The UC execution is always supplied without cable gland

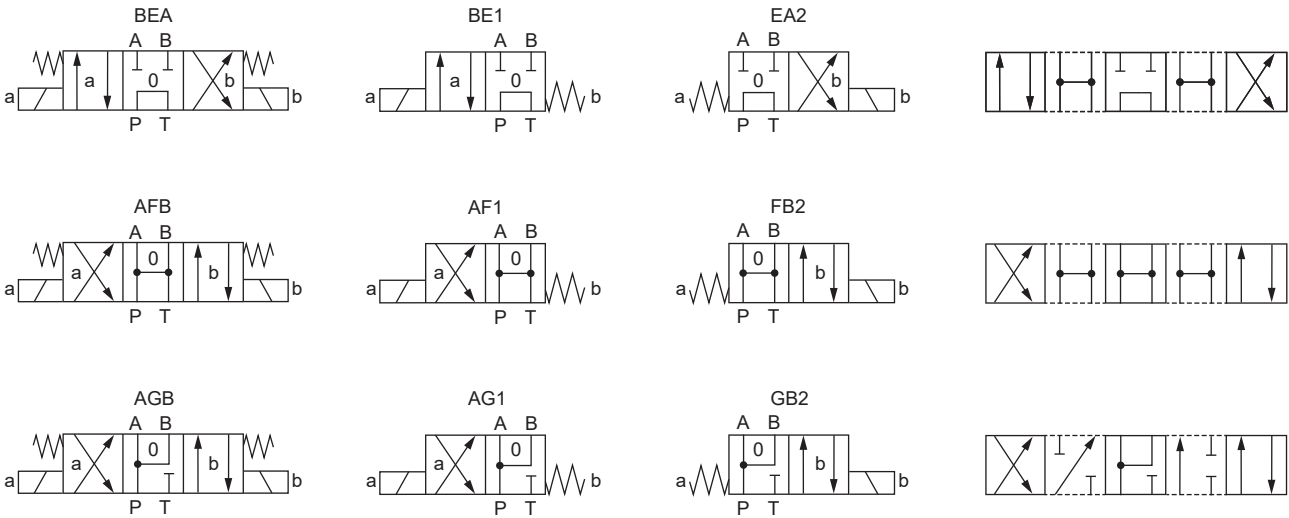

**SYMBOL**

**TYPE CODE**

		WD Y F A04 - <input type="text"/> - <input type="text"/> - <input type="text"/> / <input type="text"/> / <input type="text"/> - <input type="text"/> # <input type="text"/>				
Spool valve direct operated						
Explosion proof execution Ex d						
Flange construction						
NG4-Mini to Wandfluh standard						
Designation of symbols acc. to table						
Spool specification	Standard <input type="checkbox"/>					
	Low Leakage <input type="checkbox"/> 1/x					
Nominal voltage $U_N$	12 VDC <input type="checkbox"/> G12	115 VAC <input type="checkbox"/> R115				
	24 VDC <input type="checkbox"/> G24	230 VAC <input type="checkbox"/> R230				
Nominal power $P_N$	9 W <input type="checkbox"/> L9	<i>Ambient temperature up to:</i> 40 °C or 90 °C				
	15 W <input type="checkbox"/> L15					70 °C
Certification	ATEX, UKEX, IECEX, CCC, EAC <input type="checkbox"/>					
	Australia <input type="checkbox"/> AU					USA / Canada <input type="checkbox"/> UC-M187
	MA <input type="checkbox"/> MA					India <input type="checkbox"/> PE
Sealing material	NBR <input type="checkbox"/>					
	FKM (Viton) <input type="checkbox"/> D1					
	NBR -40 °C <input type="checkbox"/> y-Z604					(only with 15 W)
Design index (subject to change)						

1.3-24

## GENERAL SPECIFICATIONS

Designation	4/2-, 4/3-spool valve
Construction	Direct operated
Mounting	Flange construction
Nominal size	NG4-Mini according to Wandfluh standard
Actuation	Ex-protection switching solenoid
Ambient temperature	<b>Operation as T6</b> -25...+40 °C (L9) <b>Operation as T4</b> -25...+90 °C (L9) -25...+70 °C (L15) -40...+70 °C (L15)
Weight	2,6 kg (1 solenoid) 4,4 kg (2 solenoids)
MTTFd	150 years

## ELECTRICAL SPECIFICATIONS

Protection class	IP65 / 66 / 67
Relative duty factor	100 % DF
Switching frequency	12'000 / h
Voltage tolerance	± 10 % with regard to nominal voltage
Standard nominal voltage	12 VDC, 24VDC, 115 VAC, 230 VAC AC = 50 to 60 Hz ± 2 %, with built-in two-way rectifier
Standard nominal power	9 W, 15 W
Temperature class	Nominal power 9 W: T1...T6 Nominal power 15 W: T1...T4

**Note!** Other electrical specifications see data sheet 1.1-183



## PERFORMANCE SPECIFICATIONS

Oil viscosity  $\nu = 30 \text{ mm}^2/\text{s}$

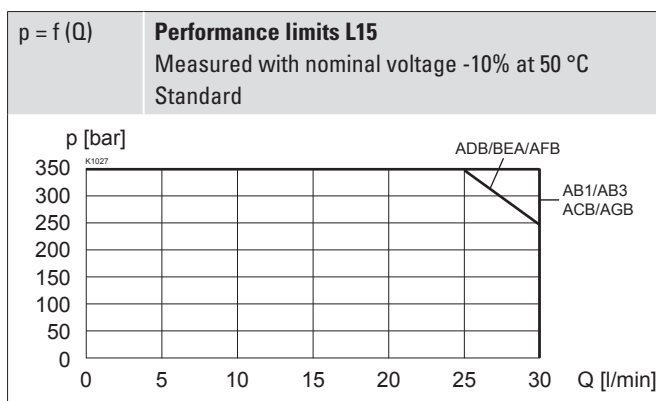

## HYDRAULIC SPECIFICATIONS

Working pressure	$p_{\max} = 350 \text{ bar}$ ( $p_T < 20 \text{ bar}$ ) $p_{\max} = 315 \text{ bar}$ ( $p_T > 20 \text{ bar}$ )
Tank pressure	$p_{T\max} = 160 \text{ bar}$
Maximum volume flow	$Q_{\max} = 30 \text{ l/min}$ , see characteristic
Leakage oil	See characteristics
Fluid	Mineral oil, other fluid on request
Viscosity range	12 mm <sup>2</sup> /s...320 mm <sup>2</sup> /s
Temperature range fluid	<b>Operation as T6</b> NBR -25...+40 °C (L9) FKM -20...+40 °C (L9) <b>Operation as T4</b> NBR -25...+70 °C (L9 or L15) FKM -20...+70 °C (L9 or L15) NBR 872 -40...+70 °C (L15)
Contamination efficiency	Class 20 / 18 / 14
Filtration	Required filtration grade $\beta_{10...16} \geq 75$ , see data sheet 1.0-50

## MANUAL OVERRIDE

HB6 as standard  
 Optionally: HN (K)  
 → see data sheet 1.1-311

## SURFACE TREATMENT

- ◆ The valve body is painted with a two component paint
- ◆ The armature tube, the slip-on coil and the plug screw are zinc-nickel coated

## COMMISSIONING

**Attention!** The solenoid coil must only be put into operation, if the requirements of the operating instructions supplied are observed to their full extent. In case of non-observance, no liability can be assumed.

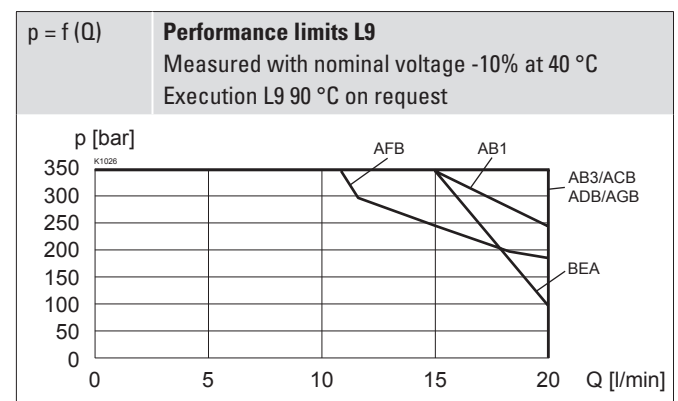

**PERFORMANCE SPECIFICATIONS**

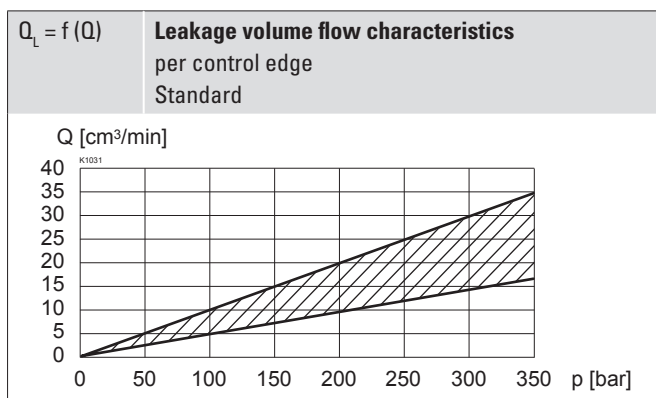
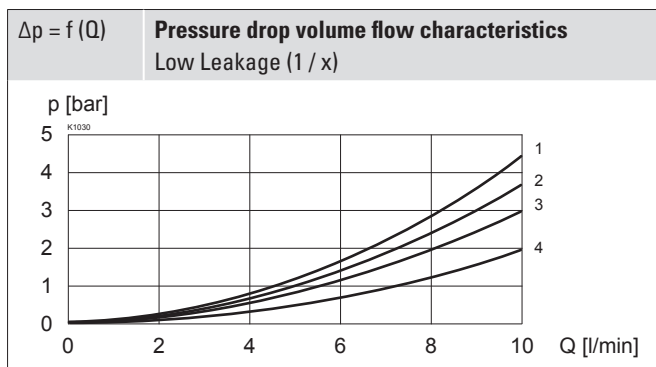
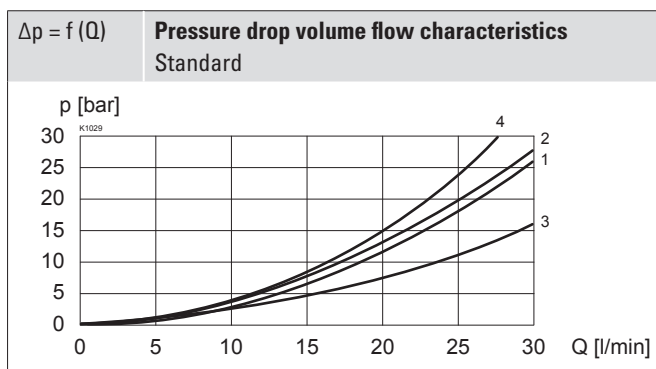
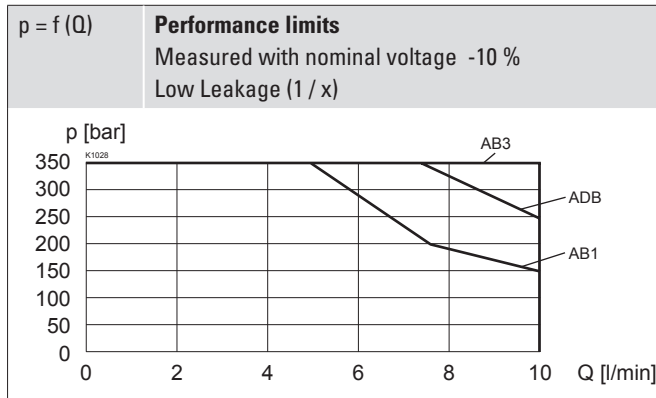
 Oil viscosity  $\nu = 30 \text{ mm}^2/\text{s}$ 

Symbol	Flow direction				
	P - A	P - B	P - T	A - T	B - T
AB1	2	2	-	1	1
AB3	2	2	-	1	1
ACB	2	2	-	1	1
ADB	2	2	-	1	1
BEA	1	1	4	1	1
AFB	1	1	3	1	1
AGB	1	1	-	1	1

Symbol	Flow direction				
	P - A	P - B	P - T	A - T	B - T
AB1	1	1	-	1	2
AB3	1	1	-	1	2
ADB	1	1	-	4	3

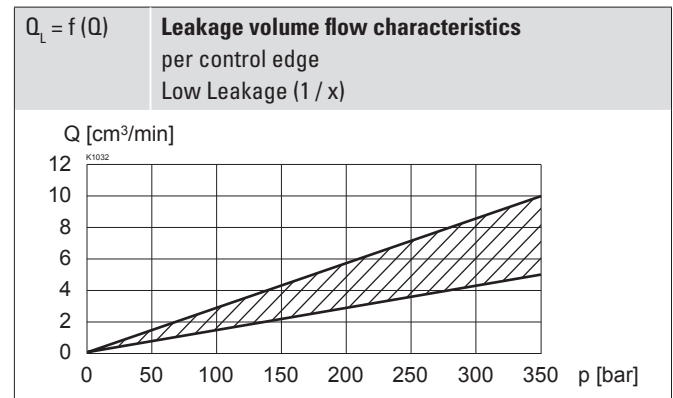
**Note!**

With the L15 execution for ambient temperatures up to 70 °C, the performance specifications have been evaluated with an ambient temperature of 50 °C

**Attention!**

For valves for the temperature ranges „-40 °C to...“ (Z604) the leakage volume flow can be up to eight times higher.

## INSTALLATION NOTES

Mounting type	Flange mounting 3 fixing holes for socket head screws M5 x 40 or M5 x 50 (with distance plate BDP4/12)
Mounting position	Any, preferably horizontal
Tightening torque	Fixing screws $M_D = 5,2 \text{ Nm}$ (screw quality 8.8, zinc coated) $M_D = 9 \text{ Nm}$ knurled nut

**Note!** The length of the fixing screw depends on the base material of the connection element.



**Attention!** For stack assembly please observe the remarks in the operating instructions



## SEALING MATERIAL

NBR or FKM (Viton) as standard, choice in the type code

## DIMENSIONS

4/3-way spool valve (spring centring)

4/2-way spool valve (impulse)

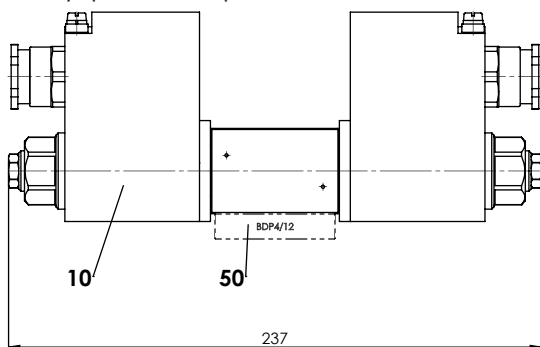

Dimensions of the solenoid coil see data sheet 1.1-183 and 1.1-184  
The distance plate BDP4/12 has to be ordered separately

## PARTS LIST

Position	Article	Description
10	263.6...	Solenoid coil MK.45 / 18 x 60
12	154.2603	Knurled nut Ex M18 x 1,5 x 18
15	253.8001	HB6 Manual override „-25 °C to...”
	253.8025	HB6-Z604 Manual override „-40 °C to...”
50	173.1450	Distance plate BDP4 / 12
110	111.1080	Cable gland M20 x 1,5
	251.2218	Seal kit WDYFA

### Seal kit consisting of:

17	O-ring	ID 25,07 x 2,62
18	O-ring	ID 17,17 x 1,78
70	O-ring	ID 5,28 x 1,78

## STANDARDS

Explosion protection	Directive 2014 / 34 / EU (ATEX)
Flameproof enclosure	EN / IEC / UL 60079-1, 31
Cable entry	EN 60079-0, 1, 7, 15, 31
Mounting interface	Wandfluh standard
Protection class	EN 60 529
Contamination efficiency	ISO 4406

## ACCESSORIES

Fixing screws	Data sheet 1.0-60
Threaded subplates	Data sheet 2.9-10
Multi-station subplates	Data sheet 2.9-50
Module type manifold blocks	Data sheet 2.9-90
Technical explanations	Data sheet 1.0-100
Filtration	Data sheet 1.0-50
Relative duty factor	Data sheet 1.1-430

4/2-way spool valve (spring reset)

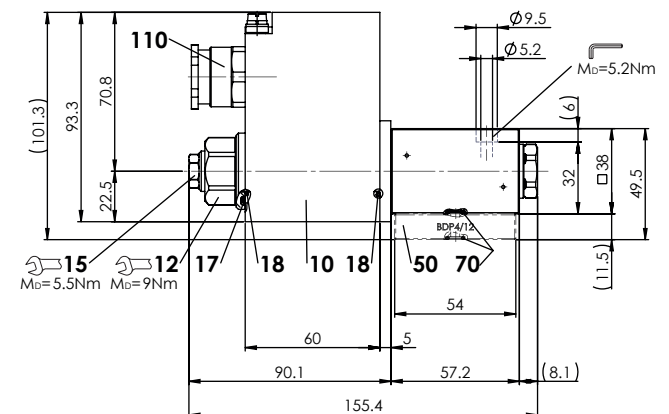

## HYDRAULIC CONNECTION

