

Proportional spool valve

Flange construction

- ◆ pilot operated
- ◆ $Q_{max} = 200 \text{ l/min}$
- ◆ $Q_{Nmax} = 90 \text{ l/min}$
- ◆ $p_{max} = 350 \text{ bar}$

NG10

ISO 4401-05

- Ex db IIC T6, T4 Gb (Zone 1)
- Ex tb III C T80 °C, T130 °C Db (Zone 21)
- Ex db I Mb
- ⊕ II 2 G Ex db IIC T6, T4
- ⊕ II 2 D Ex tb III C T80 °C, T130 °C
- ⊕ I M2 Ex db I Mb
- Class I, Division 1, Group A, B, C, D T4
- Class II & III, Division I, Group E, F, G T4

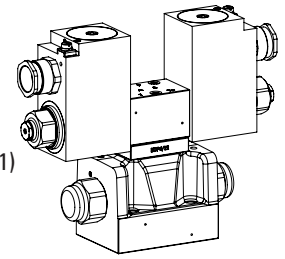

DESCRIPTION

Pilot operated proportional spool valve with 4 connections in 5-chamber system. Very compact construction with corresponding low weight and high flow values. The function of the pilot and main valve as well as the interaction of both valves can be found in the hydraulic diagram. Proportional to the solenoid current, the spool stroke, the spool opening and the valve volume flow increase. The pressure tight encapsulated Ex-protection solenoid coil prevents an explosion on the inside penetrating to the outside as well as an ignitable surface temperature. For the control, Wandfluh proportional pressure valves (see register 2.3) and Wandfluh proportional amplifiers (see register 1.13) are available.

APPLICATION

These valves are suitable for applications in explosion-hazard areas, open cast and also in mines. Pilot operated valves are used where large volume flows have to be controlled. Due to the large flow range and the high stiffness of the actuation as a result of the pilot control, these valves are suitable for applications where fast acceleration and deceleration processes, high speeds and sensitive motion sequences are required. The applications are in the industrial as well as in the mobile hydraulics for the smooth control of hydraulic actuations.

CERTIFICATES

	Surface	Mining	Standard -25 °C to...	M248 Electronic
ATEX / UKEX	x	x	x	x
IECEX	x	x	x	x
CCC	x	x	x	x
EAC	x	x	x	x
Australia	x	x	x	
MA		x	x	x
USA / Canada	x		x	x
PESO	x		x	x

The certificates can be found on www.wandfluh.com

ACTUATION

- Pressure reducing valve
- MDBFA04-P / AB-25 for BCA-S / BDA-V
- MDBFA04-P / B-25 for BC1-S / BD1-V
- MDBFA04-P / A-25 for CA2-S / DA2-V

Attention! The UC execution is always supplied without cable gland



SYMBOL

Symmetrical control

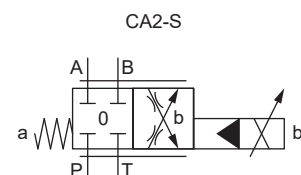
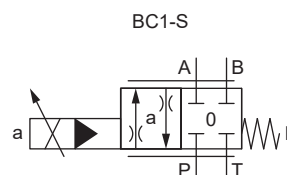
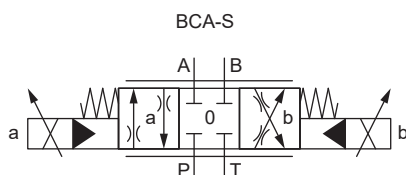

Meter-in control

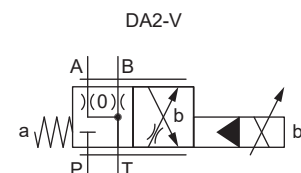
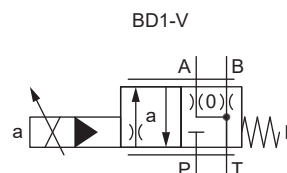
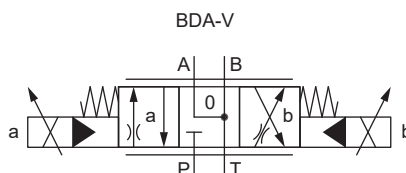

Types of pilot operation

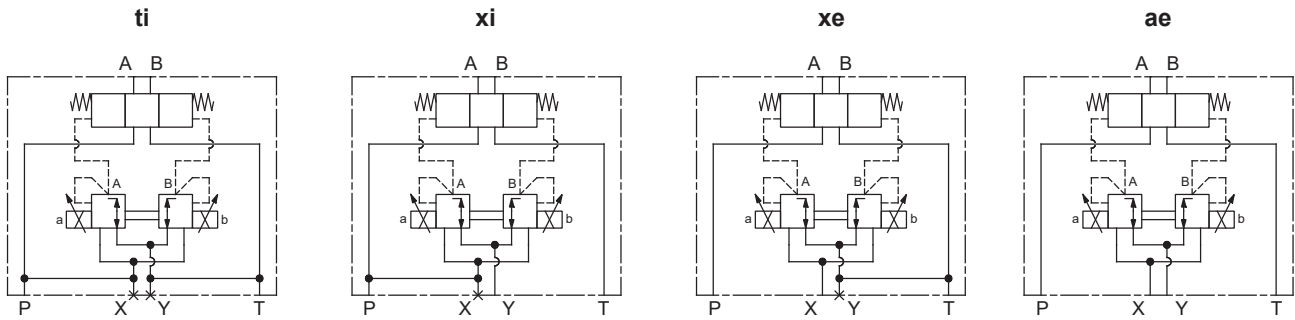
TYPE CODE

Spool valve, pilot operated, proportional, ex-protection execution Ex d		WVB F A10 - <input type="text"/> - <input type="text"/> - <input type="text"/> - <input type="text"/> / <input type="text"/> <input type="text"/> <input type="text"/> <input type="text"/> # <input type="text"/>	
Flange construction			
International standard interface ISO NG10			
Designation of symbols acc. to table			
Nominal volume flow	60 l/min (L9) <input type="text"/> 60 90 l/min (L15 / 17) <input type="text"/> 90		
Type of pilot operation:			
Control oil supply (x) and drain (y)	(x) and (y) internally <input type="text"/> ti (x) and (y) externally <input type="text"/> ae (x) internally (y) externally <input type="text"/> xi (x) externally (y) internally <input type="text"/> xe		
Nominal voltage U _N	12 VDC <input type="text"/> G12 24 VDC <input type="text"/> G24		
Nominal power P _N	9 W <input type="text"/> L9 15 W <input type="text"/> L15	Ambient temperature up to: 40 °C or 90 °C 70 °C	
Certification	ATEX, UKEX, IECEx, CCC, EAC <input type="text"/> Australia <input type="text"/> AU MA <input type="text"/> MA	USA / Canada <input type="text"/> UC-M187 India <input type="text"/> PE	
Sealing material	NBR <input type="text"/> FKM (Viton) <input type="text"/> D1		
Amplifier	<input type="text"/> M248		
Design index (subject to change)			
1.10-3520			

ACCESSORIES

Fixing screws	Data sheet 1.0-60
Threaded subplates	Data sheet 2.9-40
Multi-station subplates	Data sheet 2.9-70
Horizontal mounting blocks	Data sheet 2.9-110
Technical explanations	Data sheet 1.0-100
Filtration	Data sheet 1.0-50

STANDARDS

Explosion protection	Directive 2014 / 34 / EU (ATEX)
Flameproof enclosure	EN / IEC / UL 60079-1, 31
Cable entry	EN 60079-0, 1, 7, 15, 31
Mounting interface	ISO 4401-05
Protection class	EN 60 529
Contamination efficiency	ISO 4406

GENERAL SPECIFICATIONS

Designation	Proportional spool valve
Construction	Pilot operated
Mounting	Flange construction
Nominal size	NG10 according to ISO 4401-05
Actuation	Ex-protection proportional solenoid
Ambient temperature	Operation as T6 -25...+40 °C (L9) Operation as T4 -25...+90 °C (L9) -25...+70 °C (L15)
Weight	5,2 kg (1 solenoid) 7,0 kg (2 solenoids)
MTTFd	150 years

HYDRAULIC SPECIFICATIONS

Working pressure	$p_{max} = 350$ bar
Tank pressure	$p_{Tmax} = 160$ bar (type of pilot operation ae and xi) $p_{Tmax} = 100$ bar (type of pilot operation ti and xe)
Pilot pressure	$p_v = 25...350$ bar Connection X: $p_v = 25...200$ bar
Pressure pilot oil drain	Minimum 25 bar lower than p_v
Maximum volume flow	$Q_{max} = 200$ l/min, see characteristics
Leakage oil	See characteristics
Fluid	Mineral oil, other fluid on request
Viscosity range	12 mm ² /s...320 mm ² /s
Temperature range fluid	Operation as T6 NBR -25...+40 °C (L9) FKM -20...+40 °C (L9) Operation as T4 NBR -25...+70 °C (L9 or L15) FKM -20...+70 °C (L9 or L15)
Contamination efficiency	Class 18 / 16 / 13
Filtration	Required filtration grade $\beta_{6...10} \geq 75$, see data sheet 1.0-50

Attention! With the execution L9 for ambient temperatures up to 90 °C (L9/90 °C), Q_N is not reached

ELECTRICAL SPECIFICATIONS

Protection class	IP65 / 66 / 67
Relative duty factor	100 % DF
Voltage tolerance	± 10 % with regard to nominal voltage
Standard nominal voltage	12 VDC, 24 VDC
Limiting current at... °C	L9, 40 °C $I_G = 625$ mA (12 VDC) $I_G = 305$ mA (24 VDC) L15, 50 °C $I_G = 950$ mA (12 VDC) $I_G = 450$ mA (24 VDC) L15, 70 °C $I_G = 910$ mA (12 VDC) $I_G = 420$ mA (24 VDC)
Standard nominal power	9 W, 15 W
Temperature class	Nominal power 9 W: T1...T6 Nominal power 15 W: T1...T4

Note! Other electrical specifications see data sheet 1.1-183

MANUAL OVERRIDE

HB4,5 as standard
Optionally: HN (K)
→ see data sheet 1.1-311

SURFACE TREATMENT

- ◆ The main valve body, the distance plate, the screw plugs, the slip-on coil and the armature tube are zinc-nickel coated
- ◆ The pilot valve body is coated with a two component paint

SEALING MATERIAL

NBR or FKM (Viton) as standard, choice in the type code

PERFORMANCE SPECIFICATIONS

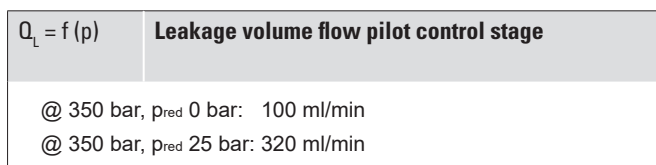
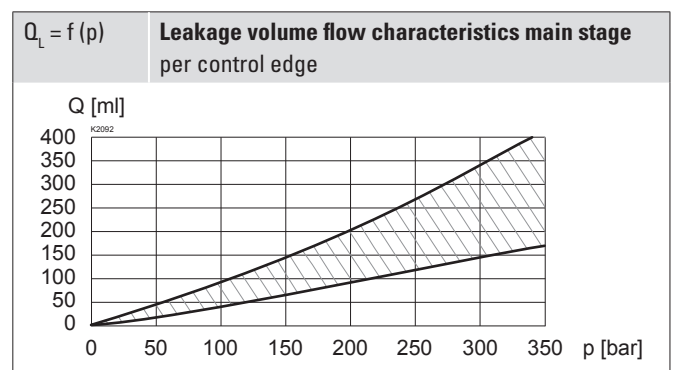
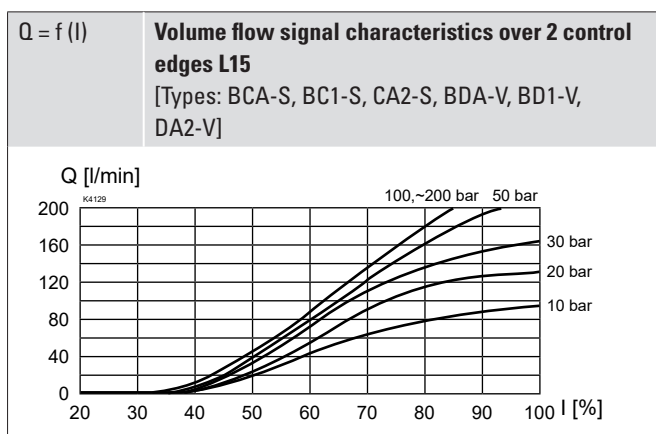
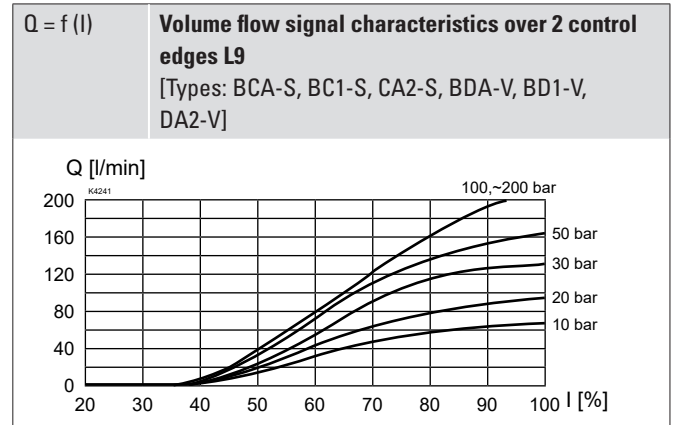
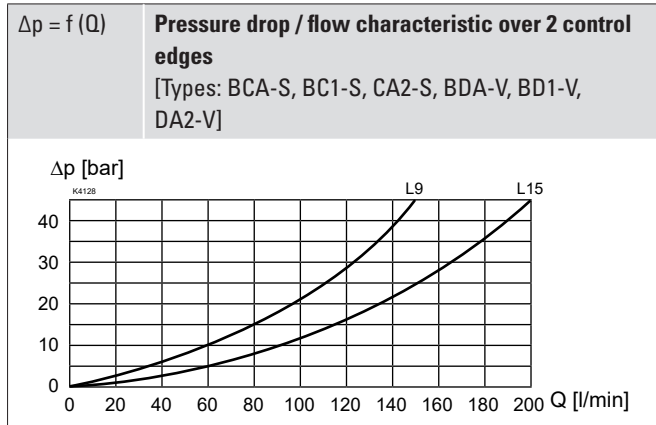
 Oil viscosity $\nu = 30 \text{ mm}^2/\text{s}$

Note!  All values were measured over two control edges. The connections A and B were short-circuited.

INSTALLATION NOTES

Mounting type	Flange mounting 4 fixing holes for socket head screws M6 x 40
Mounting position	Any, preferably horizontal
Tightening torque	$M_D = 13.5 \text{ Nm} \pm 10 \%$, quality min. 10.9 $M_D = 10.5 \text{ Nm} \pm 10 \%$, quality 8.8: <ul style="list-style-type: none"> ◆ maximum tank pressure without external connections: 80 bar ◆ maximum tank pressure and maximum pressure external connections: 35 bar

Note!  The length of the fixing screw depends on the base material of the connection element.

PARTS LIST

Position	Article	Description
20	246.2146	Socket head screw M5 x 45 DIN 912
80	173.1450	Distance plate BDP4 / 12
	251.2923	Seal kit WV.FA10

Seal kit consisting of:

30	O-ring	ID 12,42 x 1,78
40	O-ring	ID 7,65 x 1,78
60	O-Ring	ID 5,28 x 1,78

