

Spool valve intrinsically safe

Flange construction

- ◆ pilot operated
- ◆ 4/2-way impulse execution detented
- ◆ 4/3-way with spring centred mid position
- ◆ 4/2-way with spring reset
- ◆ $Q_{max} = 160 \text{ l/min}$
- ◆ $p_{max} = 350 \text{ bar}$

DESCRIPTION

Pilot operated 4-way valve in a 5 chamber system. The control of the pilot valve takes place electrically. Very compact construction with corresponding low weight. The hydraulic control of the pilot valve can be internal or external via an additional connection plate or the mounting interface depending on the type of pilot operation. Spool detented or with spring reset. Intrinsic safety is achieved by limiting the electric energy in the solenoid circuit by means of a separate intrinsically safe power supply. Therewith sparking is prevented from forming.

SYMBOL

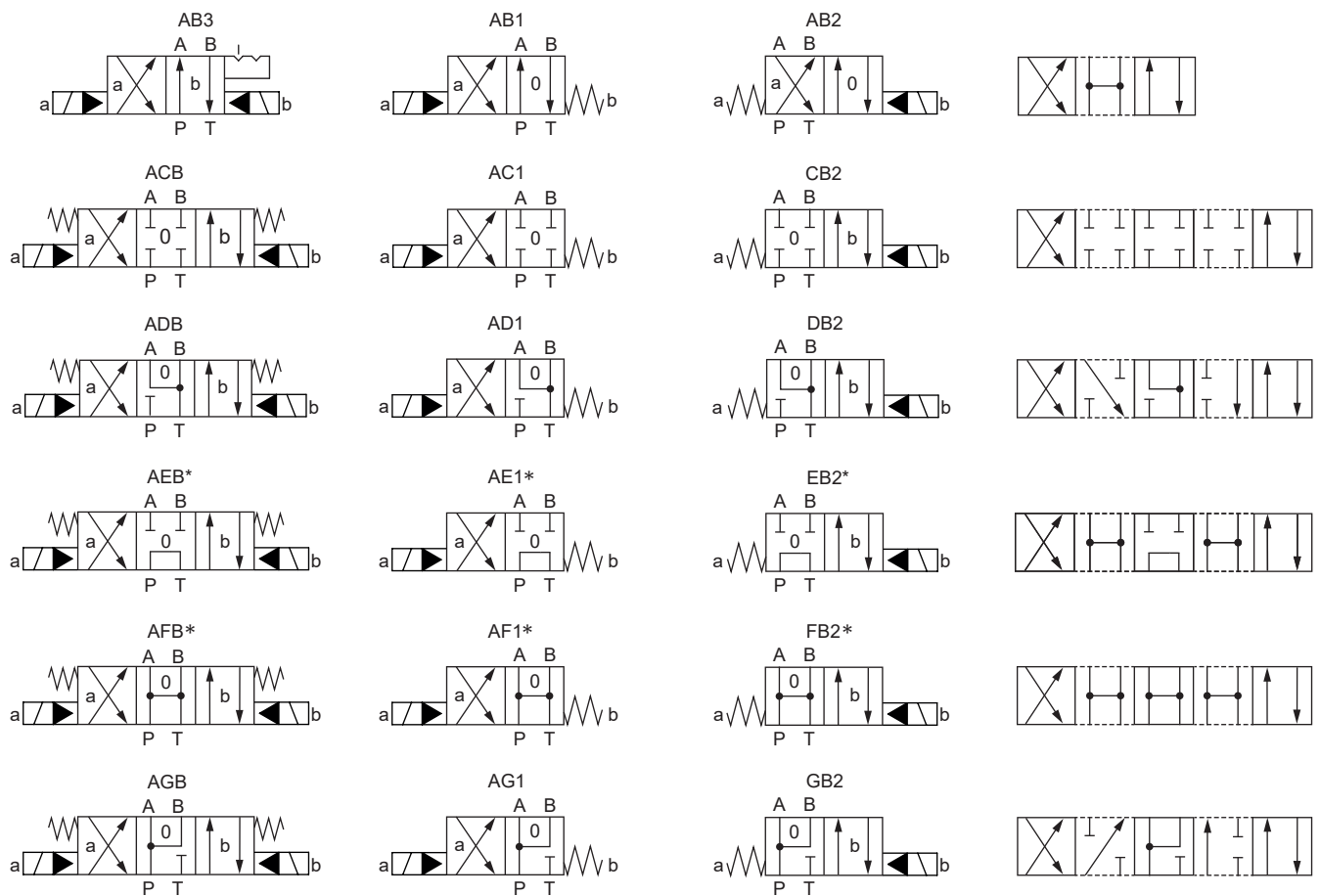

* When the connections P and T are connected in the middle position, a back pressure cartridge is built in as standard in the case of internal pilot oil supply (ti/pi). If this back pressure valve is not used (0, according to the type code), it must be ensured that a pilot pressure of minimum 4 bar is present. The pressure difference of this cartridge has to be added to the pressure difference of the main valve (see characteristics) which results in an overall value. Pilot control type xi is not available with a back pressure cartridge.

NG10 ISO 4401-05

- Ex ia I Ma
- Ex ia II C T5 / T6 Ga
- ⊕ Ex II 1 G Ex ia II C T6, T5
- ⊕ Ex I M1 Ex ia I Ma

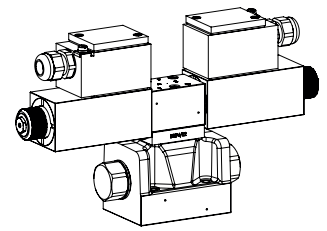

APPLICATION

These valves are suitable for applications in explosion-hazard areas, open cast and also in mines. The direction of movement is determined by the position of the spool and its symbol. Pilot operated valves are used where large volume flows have to be controlled. Switching performance and leakage of the valves must be taken into account when designing the system.

Types of pilot operation

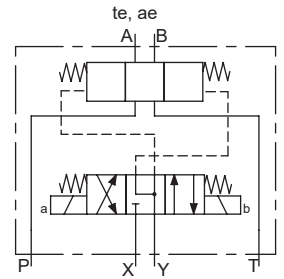
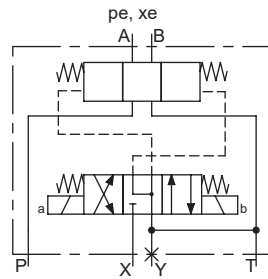
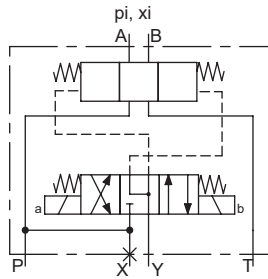
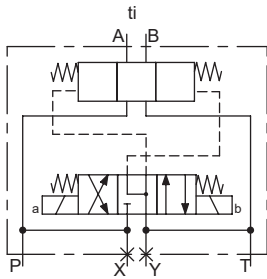

TYPE CODE

WVZ F A10 - - - - / - #

Spool valve pilot operated, Ex-protection execution Ex ia

Flange construction

International standard interface ISO NG10

Designation of symbols according to table

Back pressure cartridge Standard
only symbols AEB and AFB without back pressure see notes
cartridge cartridge section symbols

Type of pilot operation:
Control oil Supply (x) and drain (y)

(x) and (y) internally via control plate: ti

(x) and (y) externally te

(x) internally (y) externally pi

(x) externally (y) internally via mounting interface: pe

(x) and (y) externally ae

(x) and (y) externally xi

(x) externally (y) internally xe

Coil resistance 100 Ω 100
152 Ω 152

Equipment group I (Mining) Z319 only in combination with coil resistance 100 Ω
II (Surface) T6

Connection execution D
 K

Sealing material NBR
FKM (Viton) D1

Dampening orifices in control connections A and B without orifice
orifice Ø 0,5 mm 0,5 provide for control pressure above 100 bar

Design index (subject to change)

1.9-40

GENERAL SPECIFICATIONS

Designation	4/2-, 4/3-spool valve
Mounting	Flange construction
Nominal size	NG10 according to ISO 4401-05
Ambient temperature	-25...+45 °C (operation as T6) -25...+60 °C (operation as T1...T5)
Weight	5,4 kg (1 K-solenoid) 7,6 kg (2 K-solenoids)
MTTFd	150 years

HYDRAULIC SPECIFICATIONS

Working pressure	$p_{max} = 350$ bar
Tank pressure	$p_{Tmax} = 160$ bar (type of pilot operation te, pi, ae and xi) $p_{Tmax} = 100$ bar (type of pilot operation ti, pe and xe)
Pilot pressure	p_{vmin} : 8...14 bar, see performance limits $p_{vmax} = 350$ bar for connection X (control plate) $p_{vmax} = 200$ bar for connection X (mounting interface)
Pressure pilot oil drain	minimum lower by p_{vmin}
Maximum volume flow	$Q_{max} = 160$ l/min
Leakage oil	See characteristic and pilot valves
Fluid	Mineral oil, other fluid on request
Viscosity range	12 mm ² /s...320 mm ² /s
Temperature range fluid	-25...+45 °C (operation as T6, NBR) -20...+45 °C (operation as T6, FKM) -25...+60 °C (operation as T1...T5, NBR) -20...+60 °C (operation as T1...T5, FKM)
Contamination efficiency	Class 20 / 18 / 14
Filtration	Required filtration grade $\beta_{10...16} \geq 75$, see data sheet 1.0-50

MANUAL OVERRIDE

HB4,5 as standard
 Optionally: HN (K), HB0 (plugged)
 → see data sheet 1.1-311

ACTUATION

Solenoid spool valve direct operated
 Data sheet 1.3-28
 WDZFA04-AB1 / AB2 for 4/2-way AB1 / AB2
 WDZFA04-AD1 / DB2 for other 4/2-way
 WDZFA04-ADB for 4/3-way with spring centred mid position
 WDZFA04-ADB for 4/2-way impulse execution detented

ELECTRICAL SPECIFICATIONS

Protection class	IP65
Relative duty factor	Continuous operation
Switching frequency	1'800 / h
Service life time	10 ⁷ (number of switching cycles, theoretically)
Voltage tolerance	± 10 % with regard to nominal voltage
Limiting current at 50 °C	$I_{min} = 90$ mA (100 Ω execution) $I_{min} = 64$ mA (152 Ω execution)
Temperature class	T1...T6
Coil resistance	100 Ω, 152 Ω
Minimum power consumption	$P_{min} = 0,81$ W (100 Ω execution) $P_{min} = 0,62$ W (152 Ω execution)

Note!



Other electrical specifications, recommended power supply and safety-related limits see data sheet 1.1-185

CERTIFICATES

	Surface gas and dust	Mining
ATEX / UKEX	x	x
IECEX	x	x
CCC	x	x

The certificates can be found on www.wandfluh.com

PERFORMANCE SPECIFICATIONS

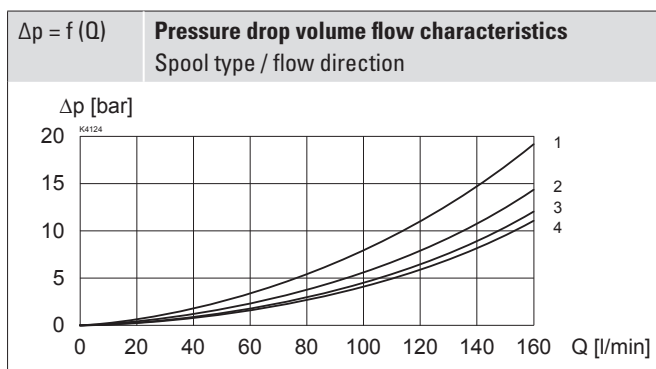
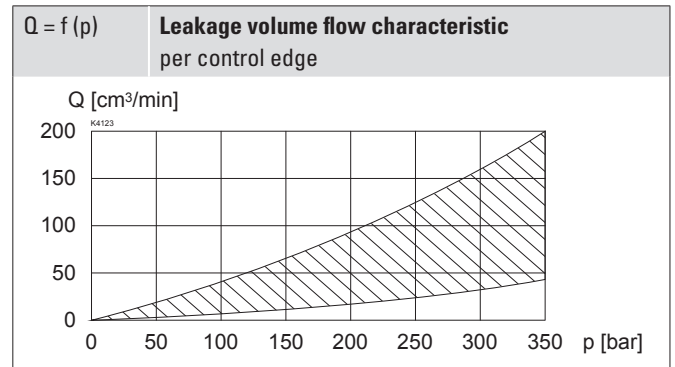
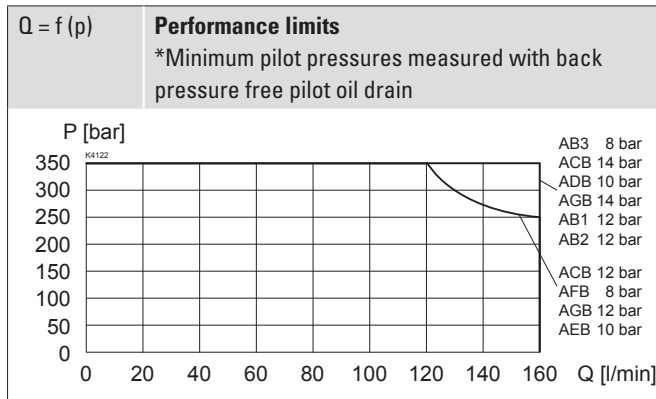
 Oil viscosity $\nu = 30 \text{ mm}^2/\text{s}$

Symbol	Volume flow direction				
	P - A	P - B	P - T	A - T	B - T
AB1 / AB2 / AB3	3	3	-	2	1
ACB / AC1 / CB2	3	3	-	2	1
ADB / AD1 / DB2	3	3	-	2	1
AEB / AE1 / EB2	3	3	1	2	1
AFB / AF1 / FB2	2	2	4	4	2
AGB / AG1 / GB2	2	2	-	2	1

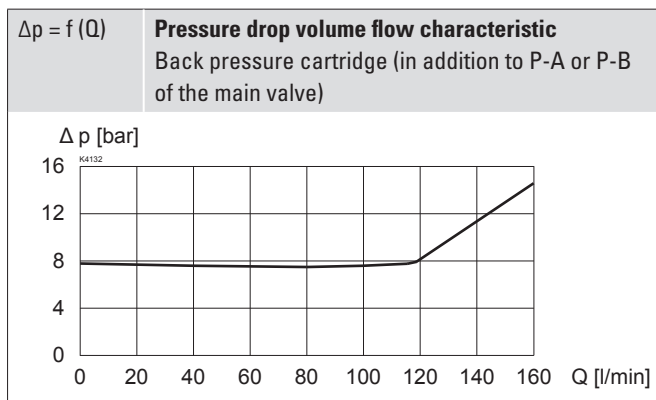
Note!

*Please ensure the minimum pilot pressure. Attention internal pilot connections: valves only switch when the pressure difference in the valve is high enough. Further details on request.

SURFACE TREATMENT

- ◆ The main valve body, the distance plate, the screw plugs, the slip-on coil and the armature tube are zinc-nickel coated
- ◆ The pilot valve body is coated with a two component paint

SEALING MATERIAL

NBR or FKM (Viton) as standard, choice in the type code

DIMENSIONS

4/3-way spool valve (spring centring)

4/2-way spool valve (impulse)

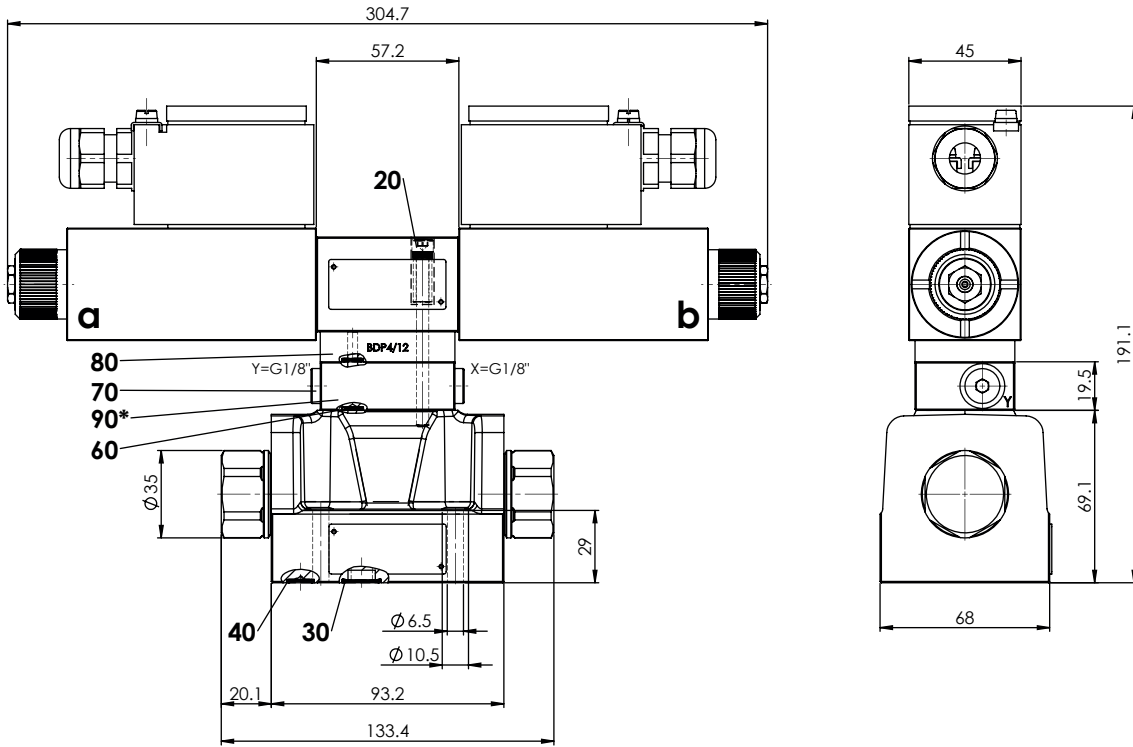

* Pos.90 Control plate with type of pilot operation te, pi, pe only

4/2-way spool valve (spring reset)

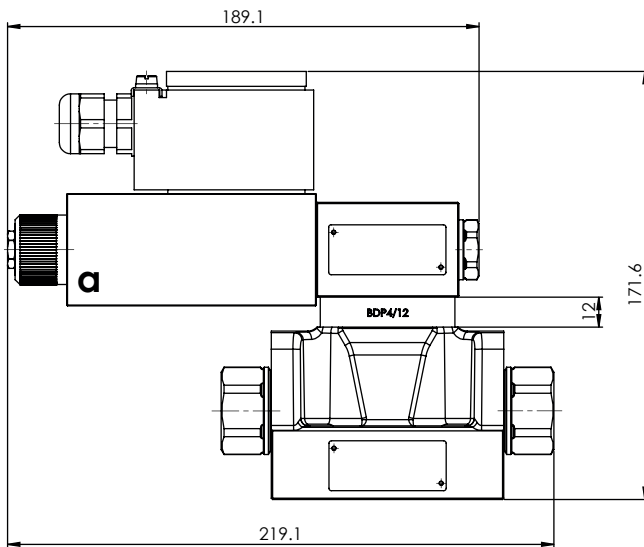

HYDRAULIC CONNECTION

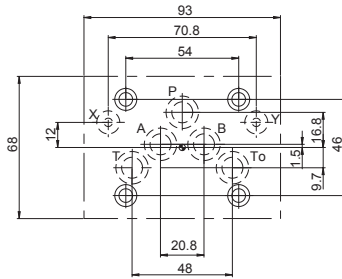

ACCESSORIES

Fixing screws	Data sheet 1.0-60
Threaded subplates	Data sheet 2.9-40
Multi-station subplates	Data sheet 2.9-70
Horizontal mounting blocks	Data sheet 2.9-110
Technical explanations	Data sheet 1.0-100
Filtration	Data sheet 1.0-50

COMMISSIONING

Attention!  Intrinsically safe valves must be controlled only by a suitable, certified power supply from out of the hazardous area (see Operating Instructions). The selection of the power supply and the wiring must be carried out by qualified personnel. Recommended power supplies and safety-related limit values according to data sheet 1.1-185

PARTS LIST

Position	Article	Description
20	246.2151	Socket head screw M5 x 50 DIN 912
	246.2171	Socket head screw M5 x 70 DIN 912
70	238.1405	Screw plug VSTI G1/8"-ED
80	173.1400	Spacer plate NG4 Mini
90	173.1500	Control plate NG4 Mini
	251.2923	Seal kit WV.FA10

Seal kit consisting of:

30	O-ring	ID 12,42 x 1,78
40	O-ring	ID 7,65 x 1,78
60	O-Ring	ID 5,28 x 1,78

STANDARDS

Explosion protection	Directive 2014 / 34 / EU (ATEX)
Mounting interface	ISO 4401-05
Protection class	EN 60 529
Contamination efficiency	ISO 4406

INSTALLATION NOTES

Mounting type	Flange mounting 4 fixing holes for socket head screws M6 x 40
Mounting position	Any, preferably horizontal
Tightening torque	$M_D = 13.5 \text{ Nm} \pm 10 \%$, quality min. 10.9 $M_D = 10.5 \text{ Nm} \pm 10 \%$, quality 8.8: ◆ maximum tank pressure without external connections: 80 bar ◆ maximum tank pressure and maximum pressure external connections: 35 bar

Note!



The length of the fixing screw depends on the base material of the connection element.