

Electronic pressure switches



CE marking

SUCO electronic switches are covered by the EMC Directive 89/336/EC.

An EC Declaration of Conformity has been issued for these pressure switches and is on file at our offices. The corresponding switches bear the CE mark in our catalogue.

- Ceramic sensor with thick film technology for high accuracy
- Electronic evaluation of switching point permits extremely small or very large hysteresis settings
- Switching point easily set by the user (menu guided for type 0570)

Technical data

	0520	0570
Switching function:	Normally open / normally closed	Normally open / normally closed, programmable, 2 switching points, time-delayed switching, zero-resetting, peak-value memory (within setting range), switching-point counter
Hysteresis:	2 – 95 % programmable at our works (max. tolerance ± 1.0 % full scale)	1 – 99 % programmable using key-pad
Adjustment:	Switching point can be set on site by the customer using a screw-driver via setting potentiometer when operating voltage is applied	Programmable using key-pad on front face
Outputs:	Transistor output (1.4 A DC12 / PNP)	2 transistor outputs (each 1.4 A DC12 / PNP) 1 analogue output (4 – 20 mA)
Indication of output status:	–	By 2 LEDs (yellow)
Time-delayed switching:	–	Adjustable 0 – 3.0 s
Pressure display:	–	Current pressure can be shown in bar or PSI on 3-digit LED-display (red)
Materials:	zinc-plated steel body (CrVI-free)	Medium-contact parts anodised aluminium, body made of die-casted zinc
Access coding:	–	The switch can have a number code between 1 and 999
Supply voltage:	18 – 36 VDC	12 – 30 VDC
Degree of protection:	IP65	
Switching time:	< 4 ms	
Accuracy:	± 0.5 % (full scale at room temperature)	
Temperature range:	NBR, EPDM: -20 °C – +80 °C FKM: -5 °C – +80 °C	
Temperature compensation:	-20 °C – +80 °C, error $\leq \pm 1.5$ % overall	
Temperature drift:	± 0.2 % / 10 K	
Life expectancy:	5 x 10 ⁶ cycles	
Pressure rise rate:	≤ 1 bar / ms	
Vibration resistance:	10 g at 5 – 2000 Hz sine-wave	
Shock resistance:	294 m / s ² , 14 ms half-sine-wave to DIN 40046	
EMV:	acc. to EN 50081-1, EN 50081-2, EN 50082-2	
Weight in grams:	approx. 240 g	approx. 340 g

Degree of protection IP65

The type approval does not apply without restriction to all environmental conditions. It is the responsibility of the user to check whether the electrical connection complies with regulations other than those stated and whether it can be used for special applications which could not be foreseen by us.

Oxygen warning!

When using oxygen, the relevant safety regulations must be observed. In addition, we recommend that a maximum operating pressure of 10 bar must not be exceeded.



0520

Electronic pressure switches



- Zinc-plated steel body (CrVI-free)
- Ceramic sensor of thick film technology
- High accuracy
- Supply voltage 18 – 36 VDC
- Overpressure safe to 20 / 150 / 500 bar¹⁾
- Hysteresis programmable in our works from 2 – 95 %
- Simple, mechanical adjustment of switching point

With female thread

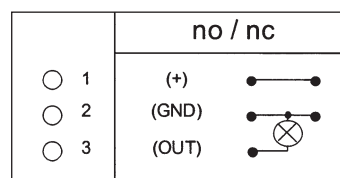

■ Our pressure switches are also available with factory pre-set switching points.

■ For further technical data and electrical values see page 55.

$p_{max.}$ in bar	Burst pressure in bar	Adjustment range in bar	Hysteresis ²⁾ in bar	Thread	Order number:
-------------------	-----------------------	-------------------------	---------------------------------	--------	---------------

0520 Electronic pressure switches normally open (no) → |:

$p_{max.}$	Burst pressure	Adjustment range	Hysteresis	Thread	Order number
20 ¹⁾	25	0 – 10	0.5 ²⁾	G 1/4 female	0520 470 14 X 001
150 ¹⁾	175	0 – 100	5 ²⁾		0520 472 14 X 001
500 ¹⁾	600	0 – 250	10 ²⁾		0520 474 14 X 001

0520 Electronic pressure switches normally closed (nc) → |:

$p_{max.}$	Burst pressure	Adjustment range	Hysteresis	Thread	Order number
20 ¹⁾	25	0 – 10	0.5 ²⁾	G 1/4 female	0520 471 14 X 001
150 ¹⁾	175	0 – 100	5 ²⁾		0520 473 14 X 001
500 ¹⁾	600	0 – 250	10 ²⁾		0520 475 14 X 001

Seal material – areas of application

NBR	Hydraulic / machine oil, heating oil, air, nitrogen etc.	1
EPDM	Brake fluid, ozone, acetylene, hydrogen etc.	2
FKM	Hydraulic fluids (HFA, HFB, HFD), petrol/gasoline etc.	3

See page 55 for temperature ranges of seal materials

Order number:	0520 -XXX 14 -X - 001
----------------------	------------------------------

¹⁾ Static pressure, dynamic pressures should be 30 to 50 % lower. These values refer to the hydraulic or pneumatic part of the pressure switch.

²⁾ Factory set, if no special customer request.

0570

Electronic pressure switches

- Anodised aluminium and zinc die-cast body
- Ceramic sensor of thick film technology
- Supply voltage 12 – 30 VDC
- Overpressure safe up to 20 / 150 / 600 bar¹⁾
- Programmable using key-pad on front side
- Time-delayed switching (adjustable 0 – 3 s)
- Peak-value memory (within setting range)
- Coding to prevent misuse



p _{max.} in bar	Burst pressure in bar	Adjustment range in bar	Thread	Order number:
-----------------------------	--------------------------	----------------------------	--------	---------------

0570 Electronic pressure switches

20 ¹⁾	25	0 – 10	G 1/4 female	0570	467	14	X	001
150 ¹⁾	175	0 – 100		0570	468	14	X	001
600 ¹⁾	700	0 – 400		0570	469	14	X	001

Seal material – areas of application

NBR	Hydraulic / machine oil, heating oil, air, nitrogen etc.	1
EPDM	Brake fluid, ozone, acetylene, hydrogen etc.	2
FKM	Hydraulic fluids (HFA, HFB, HFD), petrol/gasoline etc.	3

See page 55 for temperature ranges of seal materials

Order number:	0570 -XXX 14 -X - 001
----------------------	------------------------------

With female thread

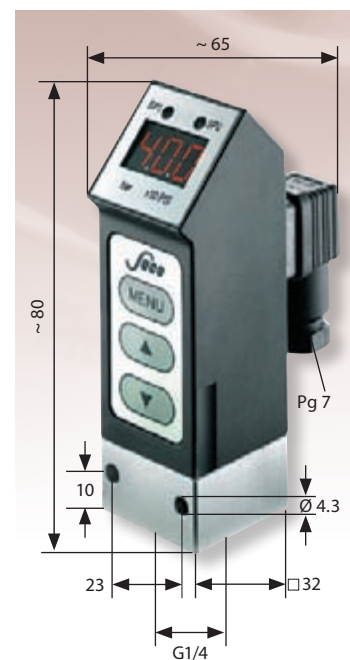

Socket device included into the scope of delivery.

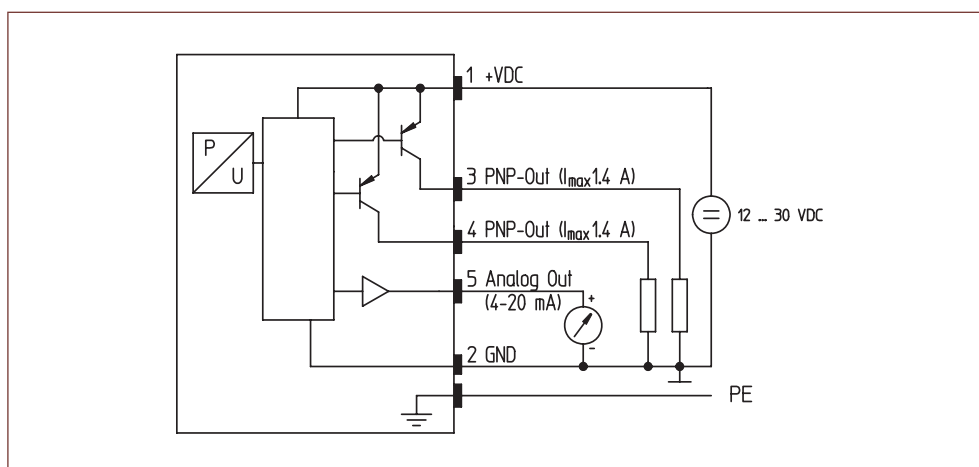

■ For further technical data and electrical values see page 55.

¹⁾ Static pressure, dynamic pressures should be 30 to 50 % lower. These values refer to the hydraulic or pneumatic part of the pressure switch.